

Technical information
Explosion drawing and parts list

Banding unit EB15-2 (Ref. 4445001)
Edition 040914H0

Pos.	Code	Item	Pos.	Code	Item	Pos.	Code	Item
1	6625024	KNOB	95	1673019	HEX. SOCKET FLAT HD. SCREW M.4X15	112	7575008	HEX. SOCKET HD. CAP SCREW M.6X25
2	1185003	HEX. NUT M.8	96	4427004	FENCE ROLLER	113	8533112	WASHER
3	1628069	REGULATING SHAFT	97	1633044	CLAMP BAR	114	8546223	AIR OUTLET PROTECTOR
4	1970001	PAN HD. TAPPING SCREW 8X1/2 PH.B.	98	2280004	WASHER D.5.2X11.1X0.7	115	1680026	WASHER D.4.3 DIN125
5	4424028	REGULATING SHAFT GUIDE	99	4426005	SPRING	116	8526102	SPRING
7	8550133	BLADES PROTECTOR	100	4428047	NUT 1/4"	117	3833085	WASHER D.8X25X3
8	2070004	PAN HD. TAPPING SCREW 6X1/4 PH.BZ	101	4875046	HEX. SOCKET HD CAP SCREW M.8X25	118	8523290	ROLLER PROTECTION
9	1675036	HEX. SOCKET SET SCREW M.8X30	102	1683004	DISC SPRING D.6.2	119	8523321	SCRAPPER
10	2023020	SPRING WASHER	103	4445042	CORD ASSY FOR MOTOR	120	8523353	GUIDE
11	2023036	WASHER	104	2973025	ALLEN SCREW M.5X15	121	3885004	SELF-LOCKING HEX. NUT M.8
12	2375001	HEX. SOCKET HD. CAP SCREW M.8X15	105	8545247	STRIP GUIDE SET	123	4875046	HEX. SOCKET HD CAP SCREW M.8X25
13	4406081	GUIDES HOLDER	106	6478002	SCREW M.4X12 PH.			
14	1675034	HEX. SOCKET HD. CAP SCREW M.8X20	107	8526096	SPRING			
15	1180003	WASHER D.8.4 DIN125	108	8526095	SPRING			
16	1627002	CENTERING COLLAR	109	7278014	SCREW M.4X8			
18	2080002	WASHER D.6.4X12.2X0.8	110	8533115	OUTLET EXTENSION			
19	1688030	SPRING PIN D.2X10	111	1580017	WASHER D.6.2X21X2			
20	8506212	UPPER GUIDE						
21	8506211	LOWER GUIDE						
22	1628051	COVER						
23	1675030	HEX. SOCKET HD. CAP SCREW M.8X30						
24	1604023	RUBBER FENCE ROLLER						
25	1628050	ROLLER SHAFT						
26	1612003	SELF LUBRICATED BEARING B-15X20X25/33						
27	1628049	KNURLED ROLLER						
28	1025101	KNOB M6X17 mm (CP)						
29	1672008	PAN HD. SCREW M.4X10 PH.						
30	8521223	TAPE GUIDE						
31	4487055	DRIVING CHAIN						
32	1604022	RUBBER INFEED ROLLER						
34	4480028	WASHER D.12.1X20X1						
35	1688015	RETAINING RING						
36	1621008	UPPER RING						
37	1621011	LOWERING						
38	1621015	GUIDE ROD						
39	1633042	WASHER						
40	8533119	DEFLECTOR						
41	1606040	MIDDLE BASE PLATE						
42	1633050	GUARD						
43	1689026	RIVET D.5X12						
44	4487052	DRIVING CHAIN						
45	4487057	GEAR 15D						
46	1675031	HEX. SOCKET SET SCREW M.6X10						
47	1687048	SPROCKET GEAR 23D						
48	4487054	SPROCKET GEAR 17D						
49	4412010	SELF LUB. BEARING B-10X14X20/18X2						
50	4488019	SHAFT						
51	4406086	SHAFT HOLDER						
52	4487053	SPROCKET GEAR 18D						
53	1675039	HEX. SOCKET HD. CAP SCREW M.5X15						
54	4406087	MOTOR HOLDER						
55	4469017	MOTOR ASSY 220 V.						
55	4469034	MOTOR ASSY 220 V. 60 HZ.						
57	8581014	WASHER D.6.1X14						
58	1675045	HEX. SOCKET HD. CAP SCREW M.6X15						
59	8588125	PIN D.1.75						
60	1633053	MAGNET LEVER						
61	1628054	PIVOT SCREW						
62	1631002	MOVABLE BLADE						
63	1628077	ROLL PIN D.6						
64	1673016	HEX. SOCKET FLAT HD. SCREW M.6X12						
65	9580005	WASHER D.10.2X20X0.26						
66	1322078	LOCK NUT						
67	1631001	FIXED BLADE						
68	1628055	ROLL PIN D.6						
69	1626042	SPRING						
70	4445079	MAGNET						
71	4427008	DISTANCE COLLAR						
72	4427006	LOCK COLLAR						
73	6345586	HEATER UNIT ASSY						
74	1628075	GUIDE ROD						
75	1633008	FAN GUIDE HOLDER						
76	1673017	HEX. SOCKET FLAT HD. SCREW M.4X10						
77	1606213	PIPE						
78	1688060	PIPE INSULATOR						
79	8533118	FAN OUTLET						
80	8533111	DISTRIBUTOR						
81	1688048	THERMOMETER						
81	3868018	THERMOMETER (F)						
82	4370046	PAN HD. TAPPING SCREW 4X3/8 PH.B.						
83	1628053	PIVOT SCREW						
84	4426039	MAGNET SPRING						
85	4445066	ROLLER HOLDER ARM						
86	4426009	SPRING						
87	9570012	PAN HD. TAPPING SCREW 8X3/8 PH.B.						
88	1675032	HEX. SOCKET HD. CAP SCREW M.4X20						
89	3883002	WASHER AET D.4.3						
90	4445070	MAGNET						
91	1612005	SELF LUBRICATED BEARING B-12X17X25/22X3						
92	1612004	SELF LUBRICATED BEARING A-12X17X25						
93	4487051	SPROCKET GEAR 15D						
94	1606057	HEATER HOLDER						

EXPLOSION DRAWING - 040915H

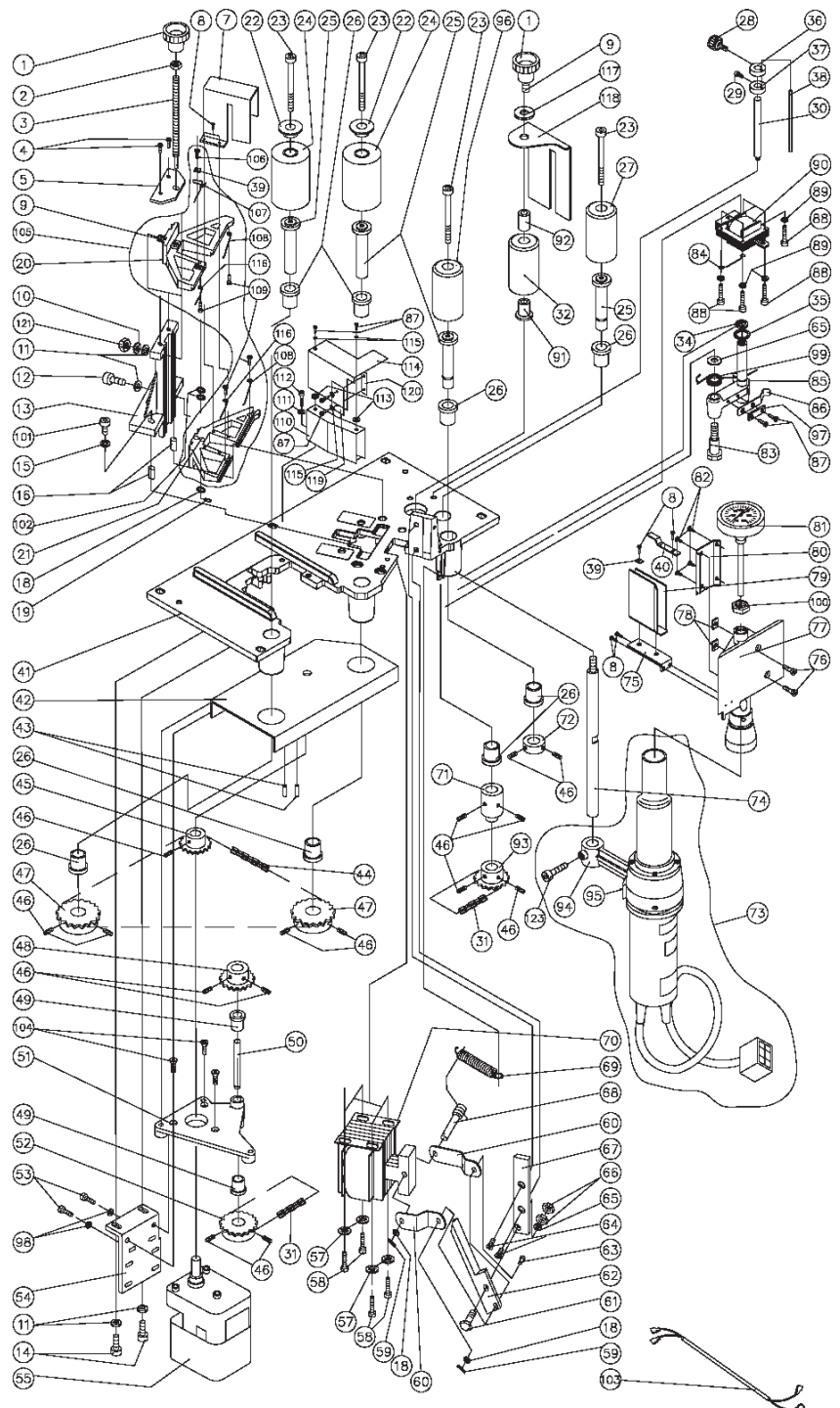

Technical information
Explosion drawing and parts list

Switch board EB15-2 (Ref. 4445002)
Edition 011120C2

Pos. Code Item

EXPLOSION DRAWING - 960116C

- 1 1668067 POTENTIOMETER KNOB
- 2 6368184 POTENTIOMETER
- 3 1324040 FELT PACKING
- 4 1370002 PAN HD. TAPPING SCREW 6X3/8 PH.BZ.
- 5 4480028 WASHER D.12.1X20X1
- 6 1615019 SWITCH
- 7 1606055 SWITCH BOARD BASE PLATE
- 8 8521223 TAPE GUIDE
- 9 4416041 SWITCH BOARD
- 10 1668070 SWITCH PROTECTION
- 11 4415021 SWITCH
- 12 4469022 INFEED TIMMER 88226.011
- 13 4302025 CORD CLAMP
- 14 1170028 PAN HD. TAPPING SCREW 8X3/4 PH.BZ.
- 15 9570012 PAN HD. TAPPING SCREW 8X3/8 PH.B.

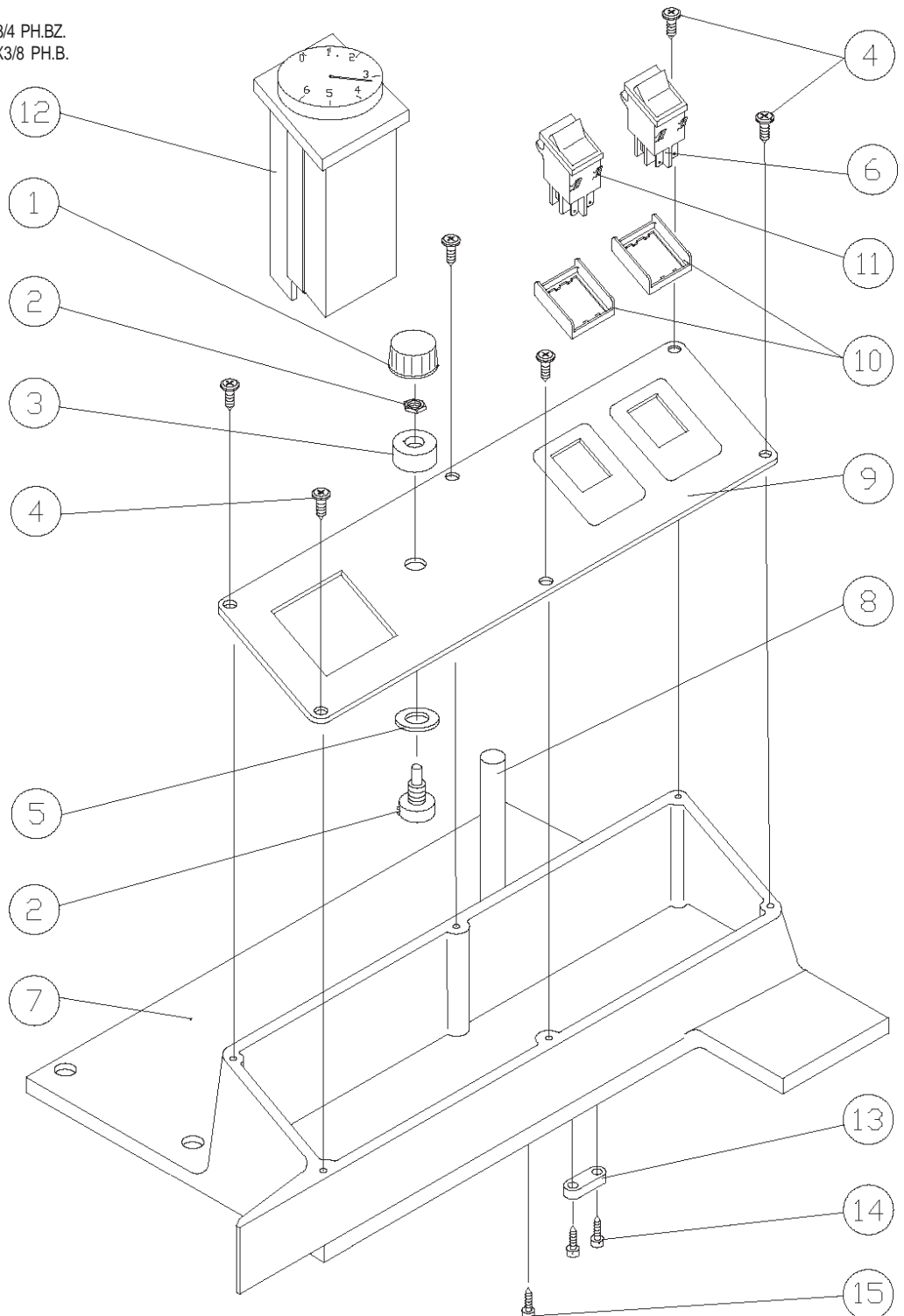

Technical information

Explosion drawing and parts list

Knives trimming unit for EB15-2 (Ref. 4445003)

Pos. Code Item

EXPLOSION DRAWING - 960125C

- 1 6625024 KNOB
- 2 2070004 PAN HD. TAPPING SCREW 6X1/4 PH.BZ
- 3 3885004 SELF-LOCKING HEX. NUT M.8
- 4 1673017 HEX. SOCKET FLAT HD. SCREW M. 4X10
- 5 1626041 SPRING
- 6 4406089 UPPER SLIDE
- 7 1633044 CLAMP BAR
- 8 2023036 WASHER
- 9 1675036 HEX. SOCKET SET SCREW M.8X30
- 10 2023020 SPRING WASHER
- 11 2375001 HEX. SOCKET HD. CAP SCREW M. 8X15
- 12 9075003 HEX. SOCKET HD. CAP SCREW M. 8X35
- 13 1180003 WASHER
- 14 4406091 HOLDDOWN BRACKET
- 16 2080002 WASHER
- 17 4406090 LOWER SLIDE
- 18 1688030 SPRING PIN D.2X10
- 19 1685017 SELF-LOCKING HEX. NUT M.6
- 20 1683004 DISC SPRING
- 21 1628057 ECCENTRIC SHAFT
- 22 1628056 BEARING COVER
- 24 1606048 LOWER BLADE HOLDER
- 25 1631003 TRIMMING BLADE (WOOD) (EB15)
- 25 1631006 TRIMMING BLADE (MELAMINE) (EB15)
- 26 1628058 FRONTAL BEARING SHAFT
- 27 1910002 BALL BEARING 608-Z
- 27 8510016 BALL BEARING 625
- 28 1684005 ARANLOCK D.5
- 29 1628066 REGULATING SHAFT
- 30 4406088 SLIDES HOLDER
- 31 1606052 UPPER BLADE HOLDER
- 32 4424047 REGULATING SHAFT GUIDE
- 33 1185003 HEX. NUT M.8
- 37 1688035 CENTERING COLLAR
- 39 1680027 WASHER
- 40 4475044 HEX. SOCKET HD. CAP SCREW M. 4X15
- 41 4475072 ALLEN SCREW M4X12

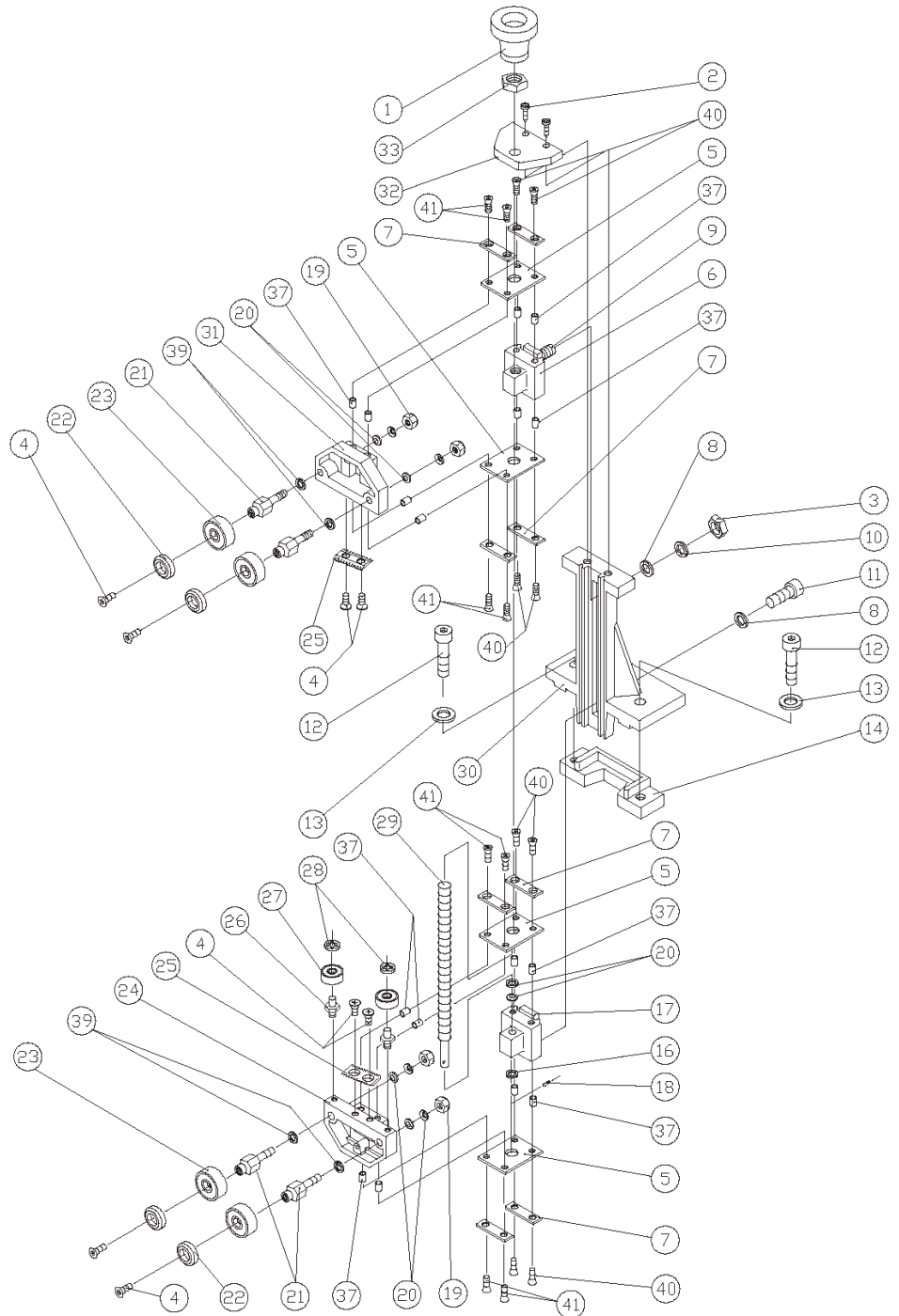

Technical information
Explosion drawing and parts list

Front trimming unit EB15-2 (Ref. 4445028)
Edition 040914B0

Pos.	Code	Item	Pos.	Code	Item
1	6307031	FRONT TRIM UNIT BASE	19	1673018	HEX. SOCKET FLAT HD. SCREW M.6X20
2	1610018	BUSHING KH 1228	20	1631005	FIXED BLADE
3	1628072	SPRING CAP	21	1322078	LOCK NUT
4	1626045	SPRING	22	1650028	FRONT END TRIMMING PROTECTION
5	1688015	RETAINING RING	23	1673016	HEX. SOCKET FLAT HD. SCREW M.6X12
6	1628089	GUIDE ROD	24	9580005	WASHER D.10.2X20X0.26
7	1675031	HEX. SOCKET SET SCREW M.6X10	25	4473021	FLAT HD. SCREW M.8X35
8	6306356	MAGNET HOLDER	26	2023036	WASHER
9	1626042	SPRING	27	4434029	MICROSWITCH HOLDER
10	3870033	PAN HD. TAPPING SCREW 4X5/8 PH.B.	28	1372016	PAN HD. SCREW M.4X6 PH.
11	4445030	MICROSWITCH	29	4428042	GUIDE ROD
12	1628074	BOLT	30	1680026	WASHER D.4.3 DIN125
13	8581014	WASHER D.6.1X14	31	1416095	LABEL
14	1675045	HEX. SOCKET HD. CAP SCREW M.6X15	32	1650050	CORD ASS'Y FOR FRONT TRIMMING STATION
15	1650049	MAGNET ASS'Y 220 V.	33	2385005	HEX. NUT M.4
16	3885004	SELF-LOCKING HEX. NUT M.8	34	6371025	HEX HD. SCREW M.4X12
17	6331016	MOVABLE BLADE			
18	1628071	PIVOT SCREW			

EXPLOSION DRAWING - 040915B

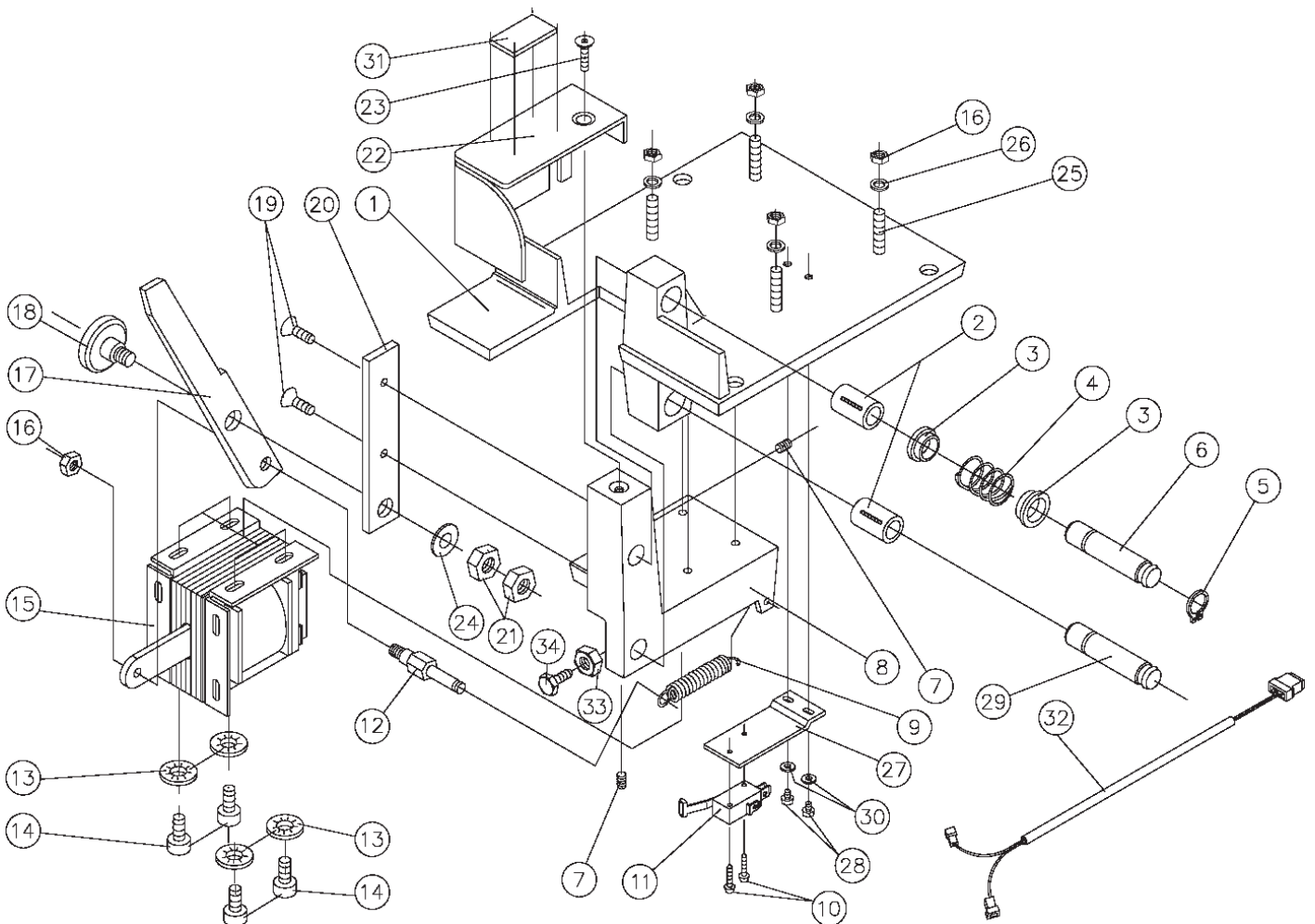

Technical information
Explosion drawing and parts list

Base ass'y EB15-2 (Ref. 4450094)
Edition 030602H0

Pos.	Code	Item	Pos.	Code	Item	Pos.	Code	Item
1	1673033	SCREW ALLEN M.6X25	33	1645045	FOOT PEDAL ASS'Y	71	4416064	WARNING LABEL
4	1685016	SQUARE NUT ASS'Y M.6	34	4445072	MAIN SWITCH	72	6368032	PLUG
5	1628091	PANEL HOLDER ARM	36	1675045	HEX. SOCKET HD. CAP SCREW M.6X15	74	6346038	GUIDE
6	3821046	ARM NUT	37	1650069	LOADER HOLDER ASS'Y	75	7575007	HEX. SOCKET HD. CAP SCREW M.6X20
8	4402198	GUIDE	39	1650024	STRIP ROLL LOADER	76	9574001	CUP SQUARE NECK BOLT M.5X15
9	3833085	WASHER D.8X25X3	43	4403012	PANEL PROTECTOR	77	7085008	HEX. NUT M.5
10	9075003	HEX. SOCKET HD. CAP SCREW M.8X35	45	4468075	PEDAL SOCKET	78	4380012	WASHER D.6.4 DIN125
12	6673010	FLAT HD. SCREW M.5X8 PH.	47	4468072	SOCKET	79	2072018	PAN HD. SCREW M.4X45 PH.
14	1623040	PRESSER HOLDER	48	1675035	HEX. SOCKET HD. CAP SCREW M.6X10	80	2385005	HEX. NUT M.4
15	1623043	PRESSER SPRING	49	4380016	WASHER D.6.3X11.8X1	81	7575008	HEX. SOCKET HD. CAP SCREW M.6X25
16	1623041	PRESSER CLAMP	54	6346045	LOWER FURNITURE ASS'Y	82	2033006	WASHER
17	7089007	WING NUT M-6	55	1650073	FURNITURE BASE ASS'Y (RIGHT)	83	8522353	BUSHING
18	4423400	SUPPORT	56	1645087	FURNITURE BASE ASS'Y (LEFT)	84	9085010	HEX. NUT M.3
19	2280004	WASHER D.5.2X11.1X0.7	57	6345516	SHEET METAL ASS'Y	85	3580010	WASHER D.3.2 DIN125
20	9588003	RETAINING RING D.4	58	4427009	RETAINING WASHER	86	4426012	SPRING
22	3802012	MICROSWITCH LEVER	59	1185003	HEX. NUT M.8	87	3874009	CUP SQUARE NECK BOLT M.6X20
24	3869001	MICROSWITCH	60	1674004	CUP SQUARE NECK BOLT M.8X70	88	8572032	SCREW M.3X20 PH
25	8526151	LEVER SPRING	61	4383008	WASHER AET D.8.4	89	6683015	BELLEVILLE WASHER D.10.2X20X0.8
26	1125003	KNOB	62	1619013	WARNING LABEL	90	9580005	WASHER D.10.2X20X0.26
27	1580017	WASHER D.6.2X21X2	63	1619014	WARNING LABEL	91	3581004	TOOTHED WASHER D.3
28	6368130	MICROSWITCH LEVER	64	1689023	RIVET D.3X6	92	8599212	COVER
29	6345242	MICROSWITCH REGULATING SUPPORT	65	1645522	ROD	93	8519333	LABEL
30	4450142	MICROSWITCH HOLDER	66	1650033	PRESSER ASS'Y	94	3525018	KNOB
31	3774011	CUP SQUARE NECK BOLT M.6X15	68	1771024	HEX. HD. SCREW M.6X15			
32	1699036	LEVELLING SHOE M.10	70	2085002	HEX. NUT M.6			

EXPLOSION DRAWING - 030603H

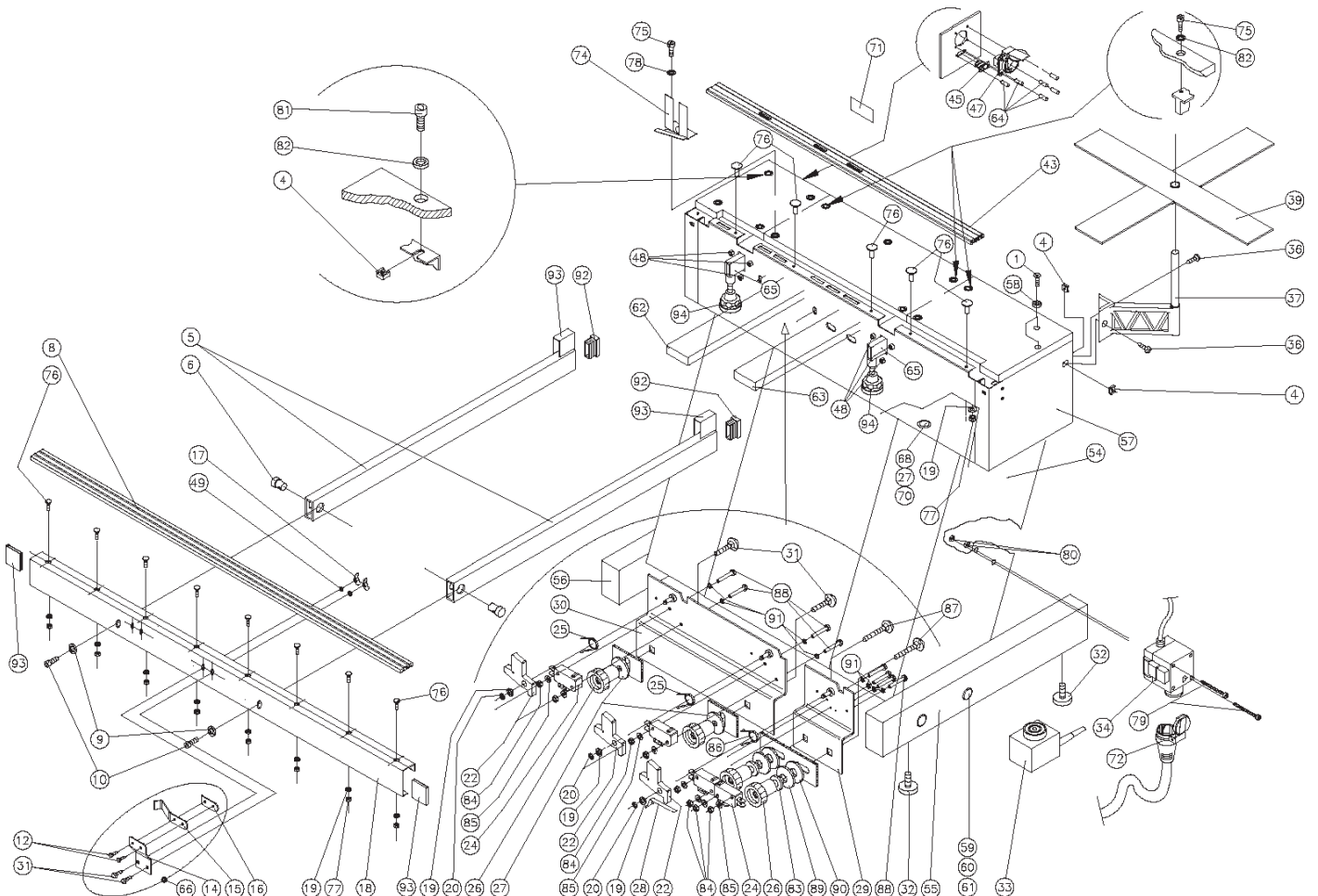

Technical information
Explosion drawing and parts list

Trimming unit AK97N for EB15-2, EB25 (Ref.6345544)
Edition 030729A0

Pos. Code Item

EXPLOSION DRAWING - 030729A

- 1 6351158 ARMATURE ASS'Y (230 V.)
- 2 4424049 DISC
- 3 4487056 BELT
- 4 4487024 PULLEY
- 5 1370002 PAN HD. TAPPING SCREW 6X3/8 PH.BZ
- 6 1233029 RETAINER
- 7 2310003 BALL BEARING 6002-ZZ
- 8 4424061 LEFT COVER
- 9 1270047 PAN HD. TAPPING SCREW 6X5/7 PH.B
- 10 4420047 SHAFT
- 11 1688015 RETAINING RING
- 13 4483006 DISC SPRING
- 14 4010005 BALL BEARING 6001 2RS
- 15 1688035 CENTERING COLLAR
- 16 4406093 BLADE HOLDER CASTING
- 17 4424057 BLADE GUARD
- 18 6478001 SCREW M.4X8 PH.
- 19 4427036 ECCENTRIC SPACER
- 20 4410021 BALL BEARING 629-ZZ
- 21 4475024 HEX. SOCKET FLAT HD. SCREW M.5X10
- 22 4475051 HEX. SOCKET SET SCREW M.5X8
- 23 4420046 BLADE HOLDER SHAFT
- 24 3885004 SELF-LOCKING HEX. NUT M.8
- 25 4404015 O-RING
- 26 4430076 SET 2 CIRCULAR BLADES
- 27 8575010 HEX. SOCKET HD. CAP SCREW M.4X8
- 28 4475044 HEX. SOCKET HD. CAP SCREW M.4X15
- 29 1633044 CLAMP BAR
- 30 1626041 SPRING
- 31 4406089 UPPER SLIDE
- 32 4406091 HOLDDOWN BRACKET
- 33 2080002 WASHER D.6.4X12.2X0.8
- 34 4406090 LOWER SLIDE
- 35 3581004 TOOTHED WASHER D.3
- 36 1210019 BALL BEARING 607 Z
- 37 1204003 BEARING HOLDER
- 38 3070036 PAN HD. TAPPING SCREW 8X5/8 PH. BZ
- 39 6355156 STATOR ASS'Y (230 V.)
- 40 7917010 CARBON BRUSHES SET
- 41 1226013 BRUSH SPRING
- 42 2070007 PAN HD. TAPPING SCREW 6X7/8 PH.BZ
- 43 4445006 CORD ASS'Y
- 44 7945034 BRUSH HOLDER ASS'Y
- 45 8545466 MOTOR HOUSING
- 46 8502427 COVER
- 47 4368022 PILLAR TERMINAL
- 48 8502428 SUPPORT
- 49 1180003 WASHER D.8.4 DIN125
- 50 9075003 HEX. SOCKET HD. CAP SCREW M.8X35
- 51 4406092 SLIDES HOLDER
- 52 3873004 FLAT HD. SCREW M.6X15
- 53 4427009 RETAINING WASHER
- 54 4424058 RIGHT COVER
- 55 2375001 HEX. SOCKET HD. CAP SCREW M.8X15
- 56 2023036 WASHER
- 57 1675036 HEX. SOCKET SET SCREW M.8X30
- 58 2023020 SPRING WASHER
- 59 4488022 RETAINING RING
- 60 3510010 BALL BEARING 6000-ZZ
- 61 4406094 BASE PLATE
- 62 3570026 PAN HD. TAPPING SCREW 6X1 1/4 PH.B.
- 63 7575008 HEX. SOCKET HD. CAP SCREW M.6X25
- 64 4487030 PULLEY
- 65 1688030 SPRING PIN D.2X10
- 66 6346163 UPPER CLEANER
- 67 4433091 RETAINER
- 68 6346164 LOWER CLEANER
- 69 6346224 PULLEY ASS'Y
- 70 4427035 REGULATING SHAFT
- 71 1185003 HEX. NUT M.8
- 72 6625024 KNOB
- 73 1383003 WASHER AET D.6.4
- 74 1683004 DISC SPRING D.6.2
- 75 4429071 ROD
- 76 7288052 O-RING D.6
- 77 8502426 MOTOR COVER
- 78 6345546 MOTOR ASS'Y AK97N
- 4494077 CARTON PACKING
- 6346187 BEARINGS CLEANER KIT

